

## RESEARCH CONCERNING THE ENSILAGE OF FODDER CROPS IN POLY-ETHYLENE BAGS

### CERCETĂRI PRIVIND ÎNSILOZAREA PLANTELOR FURAJERE ÎN FOLIE DE POLIETILENĂ

Emil VOICU\*, Virgil GÂNGU\*, Paul PÎRȘAN\*\*, Gica CIUREL\*, Alina DUMITRU\*,

\*INMA București, Romania

\*\*USAMVB, Timișoara, Romania

**Abstract:** The paper presents and analyses a new ensiling method for green fodder, by manufacturing a specialised machine which answers the pressing of chopped fodder into a polyethylene bag, in view of its ensiling. Further on, we present the working process and the main technical characteristics of green fodder ensiling machine MIF, as well as the social and, economic advantages of fodder ensiling in polyethylene.

**Rezumat:** În lucrare se prezintă și se analizează o metodă nouă de însilozare a furajelor verzi, prin realizarea unei mașini specializate care, în procesul de lucru presează furajele tocate într-un sac de polietilenă, în vederea însilozării. În continuare se prezintă procesul de lucru și principalele caracteristici tehnice ale mașinii de însilozat furaje verzi MIF, precum și avantajele socio-economice ale însilozării furajelor în polietilenă.

**Key words:** green fodder ensiling machine, rotor with spurs, carrier with scrapers

**Cuvinte cheie:** mașină de însilozat furaje verzi, rotor cu pinteni, transportor cu racleți

#### INTRODUCTION

High-yield turning vegetal production into animal production depends first of all on the quality and quantity of the fodder, factors that are determined largely by the quality of fodder crops and by the execution degree of mechanised works, particularly harvesting and preservation.

Within the concept of sustainable development of animal husbandry, livestock in general, of ruminants in particular, have a special future due to the fact that, through judicious organization, man can produce nutrients well balanced from the point of view of quality and quantity for all species and categories of farm animals.

Harvesting fodder crops is a particularly important process in the preparation of animal feed since most of the vegetal production in Romania (over 80%) is used in animal feed either directly or under the form of by-products after partial processing as raw matter in feeds.

Ensuring high quality fodder along the year is one of the basic concerns of animal breeders who, in order to diminish costs and harvesting losses and to obtain very high quality fodder, apply modern harvesting and preservation methods (technologies) through the ensilage of fodder plants, methods and technologies that only consist in the preservation of green fodder and of their nutritious value at high quality standards in the absence of air and at moisture levels between 45 and 60 %.

#### *Harvesting and ensilage technologies in fodder crops*

**Green fodder ensilage** concerns the preservation of green fodder and the preservation of their nutritious value at high standard levels in the absence of air. It presents the following advantages:

- minimal fodder losses from harvesting to animal feeding;
- integral preservation of the leaves (particularly in the case of alfalfa) that are very valuable from a nutritious point of view;

- low storage and feeding costs, doubled by low labour force requirements;
- minimal nutrient losses, with no bad weather risks when fodder is stored in the field.

The process of ensilaging green fodder is presented in Figure 1 and concerns two main phases:

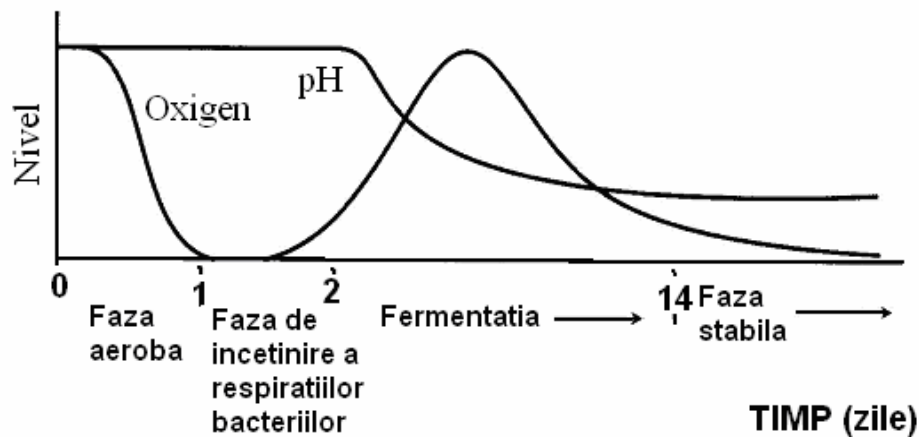

Figure 1. Fodder ensilage process

**The 1<sup>st</sup> phase, aerobic**, occurs in the presence of oxygen (air) consumed by the plants in the process of respiration. In aerobic conditions, plant enzymes and micro organisms consume the oxygen and burn carbon hydrates (sugar) soluble in the water in the plants, producing carbon dioxide and heat. This phase should be as short as possible to maintain silage quality. Excessive aerobic fermentation diminishes plant energy content and can result in protein damage (because of the heat).

**The 2<sup>nd</sup> phase, anaerobic** (fermentation) starts when the available oxygen is used in plant respiration and aerobic bacteria cease to function. Anaerobic bacteria (i.e. bacteria that develop in the absence of oxygen) start to multiply rapidly and to ferment.

The best ensilage is when micro organisms that develop rapidly are mainly lacto bacilli species, i.e. bacilli producing lactic acid from fermented plants. The lactic acid lowers the level of the pH in the matter to be ensilaged. Fermentation ceases completely after 3-4 weeks, when the pH is so low that the entire microbe development is inhibited.

In order to diminish the negative effects caused by biological and chemical processes in the silage, we recommend the application of preservation substances in the ensilage, chopped in well established amounts, using different equipment and installations that allow high distribution evenness and mixing with the fodder thus contributing to high quality ensilage.

The main *fodder crop harvesting and ensilage technologies* (Figure 2) used worldwide and in Romania are as follows:

a) *Direct harvesting with fodder combines and high moisture ensilage (60-70%)* adding, particularly in the case of alfalfa and clover, biological preservatives or chopped coarse crops (Figure 2, A);

b) *Two-phase harvesting – with the wind-rover and the combine – and low moisture ensilage (50-55%)* after naturally drying the fodder crops in the field (Figure 2, B).

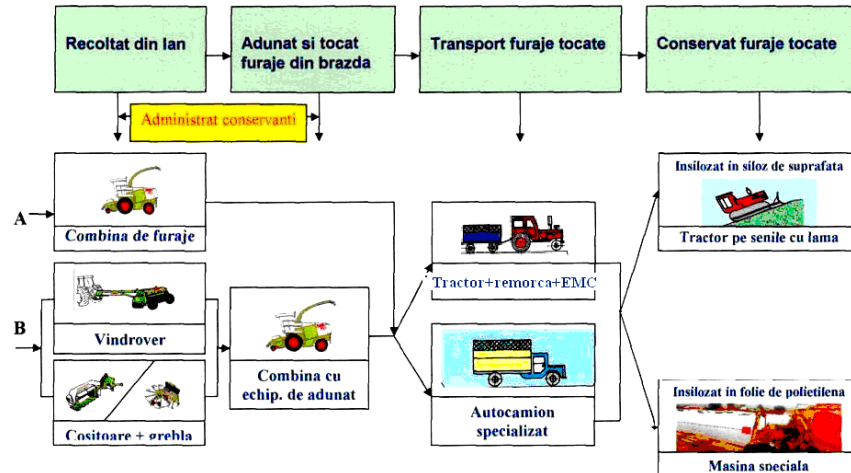

Figure 2. Green fodder harvesting and preservation technologies:  
 A – high moisture harvesting and ensilage technologies;  
 B – low moisture harvesting and ensilage technologies.

Within these technologies, direct fodder crop harvesting operations is done by fodder crop harvesting combines (self-propelled or pulled) which achieve 10-15 mm chopping (optimal chopping for ensilage) and loading of the chopped matter on carrier means. The transportation of chopped fodder from the field to the ensilage site is done with general use agricultural trailers equipped with increasing volume devices or with trucks with special bins for fodder transportation.

Classical fodder ensilage is usually done in surface silos made of concrete cells and levelling and setting of the chopped matter is done with caterpillar tractors equipped with levelling boards and of wheel tractors equipped with supplementary weighs to increase specific pressure. The capacity of these cells (silos) can be sized depending on the farm needs but no more than 1,500 t, since the filling time is high and it could result in losses. These cells cover large areas that could be used otherwise.

Re-organising the animal husbandry sector in Romania these last years led to the increase of the number of small- and medium-size private farms counting between 20 and 150 livestock, farms that do not own the areas and equipment necessary to ensilage fodder, which makes farmers adopt other advantageous solutions that meet their needs concerning the necessary feed for the entire year.

This is why the I.N.M.A. in Bucharest developed and tried a new technology for the ensilage of fodder within which chopped fodder is introduced and preserved in poly-ethylene bags having the shape of long sacks. Compared to the classical method of ensilaging fodder in concrete cells, the new method of ensilaging in poly-ethylene bags has the following advantages:

- Maintaining a high content of nutrients and vitamins in the silo by diminishing the impact of meteorological factors (sun, rain, weather, etc.);
- There is no need for special areas for the storage of silage in plastic bags;
- Plastic bag silage can be done rapidly and needs no special equipment for the levelling and setting of the chopped silage;

- We can ensilage as many fodder crops from natural meadows or pastures, as well as legume crops (alfalfa, clover, etc.), legume and graminaceae or vetch mixtures, maize, etc. as we need;

- Specific diesel consumption and the necessary labour force is low;

- Fodder losses upon ensilage and during preservation are diminished to half due to the tightness of the sack that prevents the air from entering the ensilaged fodder.

Within this technology, the I.N.M.A. also developed and tried a trial model of green fodder ensiling machine called MIF which, in the working process, takes over the chopped fodder crops, doses them and presses them into a poly-ethylene bag with a diameter of 1.8-2.0 m and different lengths depending on the farm needs.

**The MIF green fodder ensiling machine**

The MIF green fodder ensiling machine (Figure 3) is a relatively simple machine made up of a carrier with scrapers for the admission and dosage of the chopped fodder, a rotor with spurs for the pushing and pressing of the fodder into the poly-ethylene bag, a scraper, a pressing room with a sloping plane, and a mechanical transmission for the operating of the working organs. The machine is of the traction-type that works aggregated with tractors of 65-100 HP, and is powered from the tractor power plug through cardan transmission.

The main working organ of the machine is a spur rotor (Figure 4) made up of a cylinder on whose circumference are welded several spurs set in two spiralled rows surrounding the cylinder under a 180° angle. The rotor is set between two lateral walls through two bearings and its lower part is surrounded by a cylinder carcass whose angle is 60° directing the fodder towards the pressing room.



Figure 3. The MIF machine

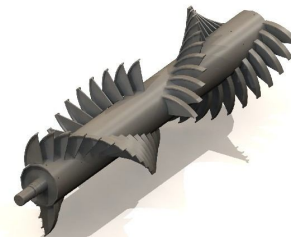

Figure 4. The MIF machine spur rotor

The main features of the MIF machine are as follows:

- Width of the scraper carrier.....2.2 m
- Working width of the spur rotor.....1.8 m
- Outer diameter of the spur rotor, mm.....540 mm
- Rotation of the spur rotor.....35 r.p.m.
- Speed of scraper carrier .....6.1 m/min
- Diameter of the poly-ethylene bag.....1.8-2.0 m
- Tractor power.....65-100 HP
- Power plug number of revolutions.....540 r.p.m.

In the working process (Figure 5), fodder chopped by fodder combines in the field are unloaded from the transportation means to the scraper carrier (2) which, due to the low speed

of the carrier belt, achieves a continuous and even feeding of the scraper rotor (3) that pushes and presses the fodder into poly-ethylene bags outside the room through a catching device (7). The rotor spurs (3) are cleaned by the comb-type scraper (4) to prevent the material from reaching the rotor back. While the bags are filled, they are set on the soil, and the machine continues to advance. Optimal density of the fodder in the bags is reached by adjusting the sloping plane (8). After filling the bags, they are tightly closed to avoid air penetration.

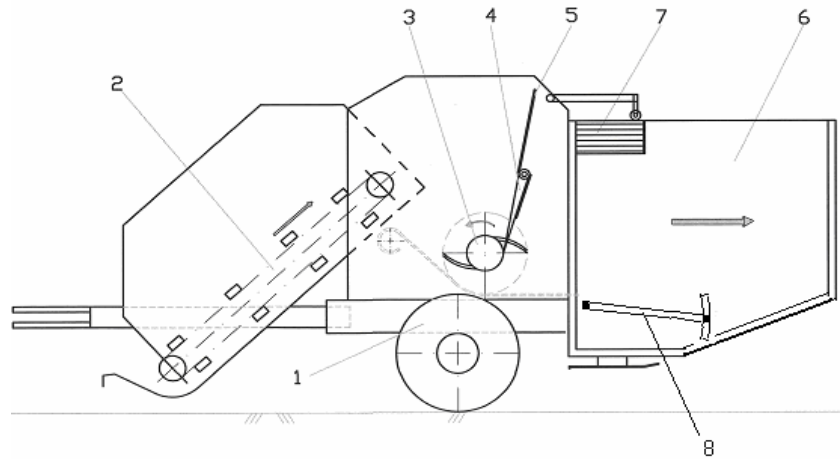

Figure 5. The MIF ensiling machine: 1 - frame; 2 - feeding carrier; 3 - spur rotor; 4 - scraper; 5 - hind wall; 6 - pressing room; 7 - bag fixing device; 8 - sloping plane

Trials with the MIF ensiling machine were carried out at the S.C. Agroindustrială Pantelimon S.A. (Ilfov County) between August and September 2007, upon silo maize ensilage. Harvesting the maize crop was done with a fodder combine Claas-Jaguar, at a moisture level of 60-65%, for a chopping length of 15 mm over 70 % the chopped volume.

Over the trials, the ensiling machine was operated by a tractor of the U 650 (65 HP) type and the chopped fodder was loaded on the carrier with the help of a frontal loader of the IFRON-204 type. For ensilage we used a poly-ethylene bag of 2 m in diameter and 30 m in length.

Trial results are presented in Table 1, and aspects of the trial period are presented in Figure 6.

Table 1

Specification	MU	Value
Ensilaged crop	-	Silage maize
Crop cutting size	mm	15 (of 70%)
Chopped crop moisture	%	60-65
Working capacity	t/h	40-45
Specific diesel consumption	l/h (l/t)	6.5-7.0 (0.15-0.17)
Operating personnel	workers (h/w/t)	2 (0.045)
Density of ensilaged fodder	kg/m <sup>3</sup>	510-540
Ensilage fodder losses	%	sub 1 %



Figure 6. Ensilage of fodder in poly-ethylene bags with the MIF machine

Analysing the data presented in Table 1, we can note the following:

- To ensilage 10-15 mm chopped (optimal size recommended for ensilage) silage maize (entire plant) the ensilage capacity was 40-45 t/h, with a specific diesel consumption of 0.15-0.17 l/t and two operators (workers, i.e. a tractor driver and a worker to survey the proper bag filling) which represents a specific labour force consumption of 0,045 h/worker/t;
- Specific weight of ensilaged fodder was 510-540 kg/m<sup>3</sup>, but the density varies in the cross section (Figure 6a), with maximum density at the bottom of the bag and minimal density at the upper part of the bag, where it reaches about 37% of the maximum density;
- Fodder losses on the whole represent 5.5%, and their distribution per works is presented in Figure 7, which shows that the largest losses are upon storage of the fodder in the silage of concrete cells where they can reach up to 10% unless we take measures to cover and protect the silage properly.

#### ***Requirements for high quality silage***

For the ensilage of the fodder in poly-ethylene bags we need to observe the following rules:

- fodder crop harvesting should be done at the optimal time, i.e. the milk wax stage for silo maize and beginning of blooming for legumes (alfalfa, clover) with a moisture level upon ensilage of 50-60%;
- the setting and storage place of poly-ethylene bags containing fodder should be neat, dry, preferably hard areas: concrete, asphalt, or even earth, as close to the consumption place as possible;
- bags should wear a producer's warranty certificate to avoid defects or other problems about using the bags;
- the use of any sharp and cutting objects on the storage area should be avoided;
- the silo should not be located near animal and/or human traffic areas;
- water near the silage should be easily removable from the spot upon choosing the silo place;
- upon setting the poly-ethylene bags on the machine attention should be paid to the blue strip controlling the elongation of the poly-ethylene sheet to control and adjust the fodder pressure force;
- during the construction of the silo, ensilaged fodder density should be adjusted to 510-540 kg/m<sup>3</sup> and maintained over the silo filling;
- right after the filling, the bag should be tightly closed to prevent oxygen penetration;

- the silage should be controlled over its entire existence to identify occasional sheet damage. Any sheet damage (holes or ruptures) should be closed with some proper scotch tape. The place near the silo should be kept clean to deter any animals that could damage the polyethylene sheet;

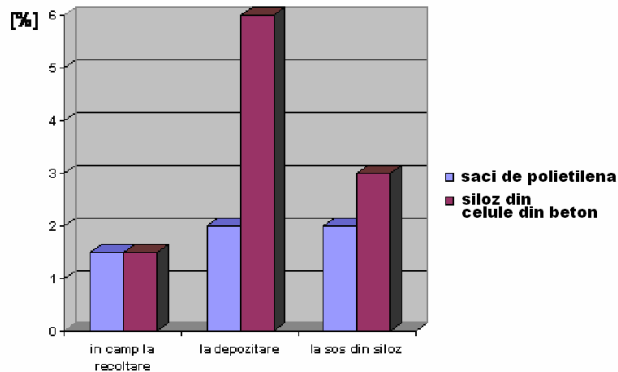

Figure 7. Distribution of fodder losses upon ensilage

- opening the bag should be done by cutting about 20 cm above the soil from the side and practicing a demy-circle over the entire transversal section. After the necessary fodder was removed, the silage is tightened again. Never cut the bag open by cutting the upper part of the bag and along the bag.

### CONCLUSIONS

As a result of the trials we carried out concerning the ensilage of fodder in polyethylene bags we can draw the following conclusions:

- the new method of ensiling fodder in poly-ethylene bags is an alternative especially for small and medium farms and for newly-established farms that do not own areas specially arranged for ensilaging fodder, thus ensuring the necessary feed with minimal expenses;

- ensiling fodder in long-size poly-ethylene bags can be done by using a 65 HP tractor to operate the ensiling machine which, in the process of ensiling, establishes the doses, fills the bags, and presses the fodder to be ensilaged with no other mechanical means to do the setting or the levelling;

- the specific ensilaged fodder volume is 510-540 kg/m<sup>3</sup> and it can be easily controlled during the ensilaging process;

- during the ensilage and over preservation, fodder losses are low, i.e. about 5% compared to the classical ensilage method (with concrete cells) where losses can reach up to 10% unless silage covering and protection measures are not taken;

- the necessary fuel and labour force is low;

- ensilage can be done over the entire fodder crop harvesting and we can ensilage both fodder plants from natural meadows or pastures as well as legumes (alfalfa and clover), mixes of legumes and graminaceae or vetch as well as *Lolium perenne*, Sudan grass, or silo maize.

### LITERATURE

1. VOICU E., PĂRȘAN P., POPESCU S., TĂNASE A., ANGHEL S. - Cercetarea și elaborarea unor tehnologii inovative pentru recoltarea și însilozarea plantelor furajere verzi, în vederea îmbunătățirii calității nutritive a hranei și a sănătății animalelor, Programul "Cercetare de excelență", contract nr. 18/03.10.2005, programul AGRAL.