

STUDIES ON THE CONSTRUCTIVE PARTICULARITIES OF THE TRACTOR U-650 M

STUDII ASUPRA PARTICULARITĂȚILOR CONSTRUCTIVE ALE TRACTORULUI U-650 M

MARIANA DUMITRU

Lucian Blaga University Sibiu, Romania

Abstract: *The research wants to emphasize the constructive particularities of the Romanian tractor U-650 M, concerning the engine, transmission, steps of speed, the work equipment and traction performances. The stage of researches is that of observing and noting down these characteristics. The methods used are those of direct measuring over a few trials. The degree of accessibility is very large, the paper being of real use for students and specialists in agriculture, in the mechanic agriculture domain.*

Rezumat: *Lucrarea dorește să evidențieze particularitățile constructive ale tractorului românesc U-650 M privind motorul, transmisia, treptele de viteză, echipamentul de lucru și performanțele de tracțiune. Stadiul cercetărilor este acela de observare și notare a respectivelor caracteristici. Metodele utilizate sunt acelea de măsurare directă în mai multe încercări. Gradul de accesibilitate este foarte mare, lucrarea prezentând un real folos pentru studenți și specialiști în domeniul mecanicii agricole.*

Key words: *engine, transmission, gear box, speed steps, traction performances*

Cuvinte cheie: *motor, transmisie, cutie de viteze, trepte de viteze, performanțe de tracțiune*

GENERAL PRESENTATION

The universal tractor on wheels U-650 M has 2 motor wheels (4 X 2) and is destined to all agricultural works for general culture, on flat ground and on declivity ground up to 14⁰. It is a middle power tractor.

The agricultural works that can be made with this tractor are:

- ✓ ploughing in aggregate with the plough
- ✓ preparing of the germinating soil works
- ✓ seeding and planting works (in aggregate with seeding and planting machines)
- ✓ works of fighting against diseases and pests (in aggregate with spreading machines)
- ✓ works of sowing, loading
- ✓ transportation works

CONSTRUCTIVE PARTICULARITIES

Tractor engine: Tractor U 650 M has a Diesel engine with direct injection, with 4 vertical cylinders in line, cooled with water, a power of 65 HP (47,8 KW). At a nominal engine rotation speed of 1800 rot/min, the total cylinder capacity is of 4760 cm³, the maximum motor moment is of 29.6 kgfm, the oiling is with pressured oil and the injection pump is linear. The general aspect of this tractor is presented in Figure 1.

Transmission: This tractor has a mechanical transmission with mechanic principal clutch with dry friction with one disk, normally coupled. The speed gear is mechanical with 5 speed steps for going forward and 1 for going backwards. Through combining with principle reducer, 2 groups of speed can be obtained: slow and rapid speeds, resulting 10+ 2 speeds.

For the nominal rotation speed of 1800 rot/min, the calculated speeds are presented in table 1:

Table 1

Speed steps from speed gear		
Speed step from speed gear	Rapid	Slow
Going forward		
1	3.90	2.64
2	6.28	4.24
3	8.70	5.87
4	11.53	7.78
5	27.32	18.43
Going backwards	4.85	3.27

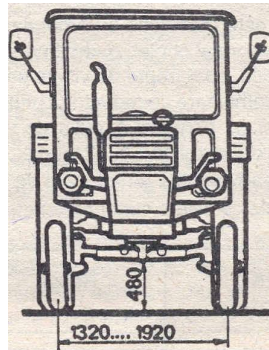
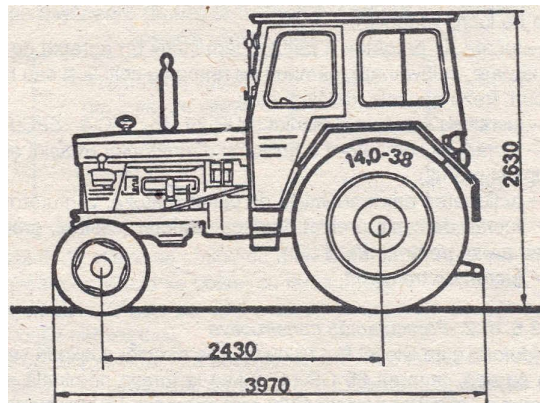

Figure 1

In case of special customize, tractor can be equipped with reducer for low speeds (2 varieties). Thus, there are obtained 2 more moving speeds (table 2).

Table 2

Moving speeds (km/h) at tractor U-650 M with low speed reducer

Variant	Speed step	Rapid	Slow
I	-	1.89	1.27
II	-	1.08	0.70

The rapid group of speed is obtained with principal reducer uncoupled.

The direction system is with is with servo-mechanism of direction or with hydrostatic direction (optionally).

The rolling system

The front axle is for direction, in a form of telescopic tubular axle with 7 possibilities for adjusting the gauge can be adjusted between 1400-2050 mm in steps continuously.

The minimum radius of turning is 3640 mm.

The breaking system

The service brakes are with disks with dry friction mounted one by one on each planetary axle, commanded independently or simultaneously through pedals and have the possibility of blocking pedals in the braked position for stationing.

The electric installation has the nominal tension of 12 V, with the negative pole connected to mass, the accumulation battery is of 12 V and 150 A.

The work equipment

The independent prize of power has a rotation speed of 540 rot/min at a nominal rotation speed of the engine of 1800 rot/min.

The hydraulic lifter can be: automatic, with Bosch distributor, automatic with distributor with rotating slide. The hydraulic lifter assures the automatic control of force and position.

The hydraulic pump is with teeth wheels and has the work pressure of 118 bar, achieving a capacity of 40 l/min. The suspension mechanism is in 3 points from category II, composed of a system of tyrants and stretching. The maximum task of lifting is 1600 kgf.

Table 3

The type of soil	The speed step	The work index at maximum traction power					
		Traction force kgf	Slipping %	Work speed Km/h	Traction power HP	Fuel consumption	
						On hour Kg/h	Specific g/CPh
Compacted soil	R1	1620	22	3.1	18.0	7.1	390
	R2	1620	22	4.9	29.0	9.2	320
	R3	1480	18	6.8	38.0	10.9	270
	R4	1200	12	9.5	43.0	11.3	250
Aired soil	R1	1100	22	2.9	12.5	6.7	600
	R2	1100	22	4.8	20.0	7.9	400
	R3	1100	22	6.7	27.0	10.3	390
	R4	880	13	9.1	31.0	10.8	345

The optional equipment is composed of:

- ✓ The belt transmission, which has 784 rot/min at a rotation speed of engine of 1800 rot/min
- ✓ Equipments of traction and trailer

✓ The pneumatic equipment for breaking the trailers
The capacity of fuel tank is 94 l. The tractor mass in the exploitation conditions is 3380 kg. The adherence can be increased by:

- ✓ Attaching weights to the front wheels and back wheels
- ✓ Attaching weights to the front traverse
- ✓ Using the automatic adjustment of force and position.

The performance of this tractor traction is presented in table 3:

CONCLUSIONS

The tractor U-650 M is a Romanian universal tractor with good parameters in functioning and exploitation, having a gear box with 10+2 steps of speed, with good parameters of traction power and fuel consumption.

REFERENCES

1. DUMITRU, M., *Tractoare agricole*, Ed. **Alma Mater**, Sibiu, 2006
2. NEDEFF, V., SIN, GH., *Construcția, exploatarea și întreținerea tractoarelor*. Ed. **Wegafor**, 1995