

## STUDY ABOUT THE POWER CONSUMPTIONS TO THE WORKS OF THE SOIL

### STUDIUL ASUPRA CONSUMURILOR ENERGETICE LA LUCRĂRILE SOLULUI

Daniel POPA, Cornelia TONEA, Gheorghe DRĂGOI, Radu ILEA,  
Lorin PILOCA, Elena TONEA, Alexandra BECHERESCU

*Universitatea de Științe Agricole și Medicină Veterinară a Banatului,  
Timișoara, Calea Arduului, 119, popadaniel67@yahoo.com*

**Abstract:** *This paperwork presents the influence of tillage methods upon fuel consumption, one of the basic requirements of a profitable agriculture. Experiments were carried out in the soil conditions of the Didactic Station from Banat's University of Agricultural Sciences and Veterinary Medicine - Timișoara (Timiș County) between and we used two soil-working methods: conventionally technology and no-tillage technology*

**Rezumat:** *În lucrare este prezentată influența metodei de lucrare a solului asupra consumului de combustibil ca o metodă de bază pentru realizarea unei agriculturi profitabile. Experimentările au fost realizate în condițiile de sol ale Stațiunii Didactice din cadrul Universității de Științe Agricole și Medicină Veterinară a Banatului din Timișoara și au vizat două metode de lucrare a solului: tehnologia convențională și tehnologii neconvenționale*

**Key words:** *fuel consumption, no-tillage system, maize crop.*

**Cuvinte cheie:** *consum de combustibil, sistem „no-tillage”, producție de porumb.*

#### INTRODUCTION

Power consumption in exploiting the equipment is twice as big as that necessary for their manufacturing. Research data show that if we want to increase agricultural production by 1% we need to increase power consumption under the form of fuel by 2.5%.

Direct drill is the most important method of saving power and of preserving the soil's production capacity. Due to the small ratio between production costs and sale price of agricultural products, more and more farmers appeal to different minimum tillage and no-till methods as means of diminishing work force, agricultural machines and fuel expenses and cultivating more.

In this paper we present a synthesis of experimental results of a study on power consumptions in different variants of working the soil compared to the direct drill method on the maize crop.

#### MATERIAL AND METHOD

The data included in the present paper are underpinned by experimental results obtained at Didactic Research Station, USAMVB Timișoara, Timiș County.

The researches were performed considering a vertic chernozem strongly gleyed presenting salinization and alkalization processes in depth (below 100 m), extremely profound on bi-stratified parental materials, middle fine, medium clayed/ medium clayed.

The soil profile shows the following sequence of horizons: Ap - Ap - Amk - A/Cyk - CykG - CyGo - CcaGo - CcaG<sub>0</sub> - CcaGr

Researches were performed on a plot located in Body I, consisted of an area of 268 ha limited in the North by the brook Beregsău, in the South by the inner land from Timișoara, and in the East and West by the national roads DN 69 Timișoara – Arad, respectively Timișoara –

Sânnicolau Mare.

The study consisted in comparing results from two soil-working systems, classical and unconventional, with the following variants:

- V<sub>1</sub> (control): tillage (depth = 20 cm) with a plough + harrowing with a disk harrow.
- V<sub>2</sub>: harrowing with a disk harrow (two times).
- V<sub>3</sub>: harrowing with a combined rotating harrow
- V<sub>4</sub>: harrowing with a disk harrow + combined rotating harrow;
- V<sub>5</sub>: harrowing with a disk harrow + vibrocultor
- V<sub>6</sub>: direct drill.

Measurement apparatuses were as follows:

- torsion moment translators (to determine the plug-in moment)
- force translators for the traction power and for the compression force, both with tension-meter timbres

Signal-conditioning apparatuses consisted of:

- amplifying modules
- data acquisition plaque
- laptop 486
- n-SOFT processing software

Block diagram with mounting to measuring devices is presented in Figure 1.

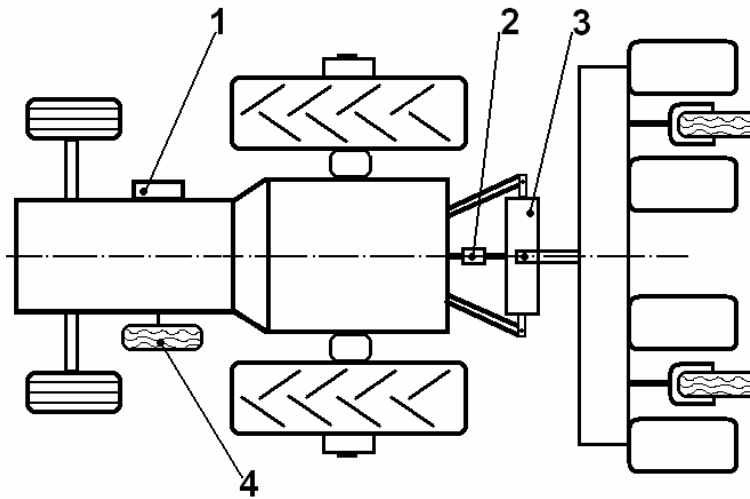

Figure 1. Experimental devices for determination energetically consumption  
1-devices for determination fuel intake; 2- converter for moment of torsion;  
3-converter for forces (switching bar); 4- inductive converter for the speed

## RESULTS AND DISCUSSION

Fuel intake is directly related to the mechanical work performed by each agricultural aggregate and depends upon the aggregate's hourly intake in various working regimes and upon it's the operating period.

The analysis of the influence of fuel intake in maize crop (Table 1) shows the differences between the experimental variants.

Table 1

Influence of tillage system on fuel intake in maize crop

Fuel consumption for technological operation (l/ha)	Tillage system						
	V <sub>1</sub> Plough + Disk harrow	V <sub>2</sub> Disk harrow x 2	V <sub>3</sub> Combined rotating harrow	V <sub>4</sub> Disk harrow+ Combined rotating harrow	V <sub>5</sub> Disk harrow+ Vibrocultor	V <sub>6</sub> Direct drill	
Basic work	29,50	35,50	39,00	38,00	41,50	-	
Germinative bed preparation	25,00						
Drill	8,25	8,25	8,25	8,25	8,25	45,80	
Maintenance, fertilization	13,00	13,00	13,00	13,00	13,00		
Chemical control upon weeds	23,50	23,50	23,50	23,50	23,50	23,50	
Harvesting	11,50	11,50	11,50	11,50	11,50	11,50	
TOTAL	l/ha	110,75	91,75	95,25	94,25	97,75	80,80
	%	100 (Mt)	82,84	86,00	85,10	88,26	72,95

The bigger fuel consumption was recorded within the classical variants with earth board plough, namely 110,75 l/ha (table 1). A fuel intake of 91,75-97,75 l/ha was recorded within the variants with minimum tillage, and it was 80,8 l/ha in the case of direct drill.

Fuel consumption, analyzed according to the main production obtained, is presented in Table 2.

Table 2

Influence of tillage system on fuel consumption in maize yield

Nr.crt.	Technological variant/ specification	Tillage system					
		V <sub>1</sub> Plough + Disk harrow	V <sub>2</sub> Disk harrow x 2	V <sub>3</sub> Combined rotating harrow	V <sub>4</sub> Disk harrow+ Combined rotating harrow	V <sub>5</sub> Disk harrow+ Vibrocultor	V <sub>6</sub> Direct drill
1	Production t/ha	8,75	8,15	8,23	8,33	8,42	7,98
2	Fuel intake l/t	12,66	11,26	11,57	11,31	11,61	10,13
3	Fuel intake %	100,00	82,84	86,00	85,10	88,26	72,96

Determinations performed show that fuel consumption decreases with 1,40-2,53 l/t in minimum tillage and direct drill variants, compared to 12,66 l/t consumed in the classical technology.

Yields in maize depending on soil working system are shown in Table 3.

Table 3

Influence of tillage system on maize yield

Nr.crt.	Specification	Tillage system					
		V <sub>1</sub> Plough + Disk harrow	V <sub>2</sub> Disk harrow x 2	V <sub>3</sub> Combined rotating harrow	V <sub>4</sub> Disk harrow+ Combined rotating harrow	V <sub>5</sub> Disk harrow+ Vibrocultor	V <sub>6</sub> Direct drill
1	Standard grain production (kg/ha)	8750	8150	8230	8335	8420	7980
2	Relative production (%)	100,00	93,14	94,05	95,25	96,22	91,20
3	Difference in production (kg/ha)	-	-600	-520	-415	-330	-770
4	Significance of differences	Mt	-	-	-	-	-

DL 5% = 779,97 Kg/ha

DL 1% = 1059,86 Kg/ha

DL 0,1% = 1436,79 Kg/ha

### **CONCLUSIONS**

1. Grain maize yield has values between 8,150-8,420 kg/ha in minimal work variants, and 7,980 kg/ha in no tillage. Compared to the classical system (8,750 kg/ha in the control), yields are lower (93,14-96,22 in the variants with minimal work, and 91,20% in no tillage variants).

2. Getting even yields or yields diminished with 5-10% compared to the classical system is considered more profitable, due firstly to the diminution of expenses on tillage, which has the greatest share in the classical system.

3. Fuel intake per total technology has the biggest values in both crops under the classical system. In maize crop, fuel savings are between 13,0-19,01 l/ha in the minimum tillage variants and 30,4 l/ha in the case of direct drill.

4. The maintenance and preservation of soil physical features through the promotion of unconventional tillage, with satisfactory yields and taking into account the significant fuel intake reductions represent a useful solution and a viable alternative, too, for the classical system due to its numerous advantages.

### **BIBLIOGRAPHY**

1. GUȘ P., RUSU T., STĂNILĂ S., 2003 - Lucrările neconvenționale ale solului și sistema de mașini, Ed. Risoprint, Cluj Napoca
2. LĂZUREANU A., 2004 - Agrotehnică, Ed. Helicon Banat, Timișoara
3. LĂZUREANU A., MANED. A., CÂRCIU GH., ALDA S., 2006 - Agrotehnică aplicativă, Ed. Eurobit, Timișoara